

V570

Measurement by volume comparison



- NEW IMPROVED PERFORMANCE
- OPTIMISED MEASUREMENT
- HIGH SPECIFICATIONS COMPETITIVELY PRICE
- EASY SET-UP

5 SERIES

Without any doubt the most advanced high performance automated volume tester on the market. Specially adapted to automatic and semi-automatic control, the **V570** has a very complete range of equipment and benefits from the use of the latest technological innovations of the 5 series of instruments.



Main features

- Measurement accuracy of a few mm³ in several litres
- Choice of operation in air or liquid volumes
- Software adjustment of the test and reference circuits through a volume auto zero
- Leak test and simultaneous measurement of volume
- High resolution mode
- Single calibration mode
- Estimation of the volume of the test part
- 16 programs
- **Serial link:** RS232: printer, P.C. and parameter save modules
- **And:** Time and date display, choice of languages and units, customisation of tests for your requirement...



Applications



General applications:

Cylinder heads, cast parts, combustion chambers, piston heads, Carburettor floats, liquid levels (bottling), measurement of filling levels (oil levels)...

Open volumes:

Cylinder head chambers, pistons...

Options

- 7 local inputs / 5 local outputs
- 1 quick connector for calibration checking
- 2 pneumatic outputs for control of sealing connectors
- 6 x 24 V programmable outputs for external connection
- 2 analogue current or voltage outputs

Measurement principles

The **V570** is composed of two equal volumes (T1 and T2) which are constantly maintained at test pressure between two measurements. Following the start of a cycle, T1 and T2 are dumped into the volume to be tested (VT) and the known reference volume (VR). After a short stabilisation time, the new differential pressure measurement is proportional to the difference between VT and VR.

Through its user friendly interface, the **V570** then displays the results of the test either in Pa or in a chosen unit of volume if the calibration procedure has taken place.

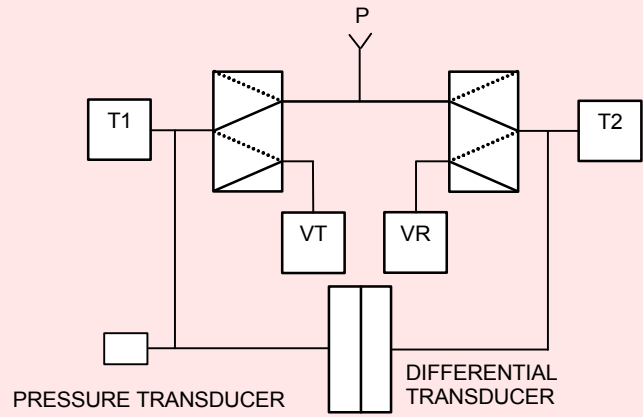

Measurement ranges

VOLUME MEASUREMENT		
RANGE	ACCURACY	MAXIMUM RESOLUTION
± 500 Pa	± 2.5 % of the full scale ± 1Pa	1 Pa

PRESSURE MEASUREMENT		
RANGE	ACCURACY	MAXIMUM RESOLUTION
5 - 75 hPa	± 1% of the full scale	0.1% F.S.

MECHANICAL PRESSURE REGULATION

from 0,5 kPa to 7,5 kPa

The base unit is the Pa. The resolution in terms of volume is inferior to 1% of the test volume. The accuracy depends on several calibration parameters. Volume range: from a few cm³ to 10 dm³ with accuracies reaching a few mm³ on small volumes of several cm³.

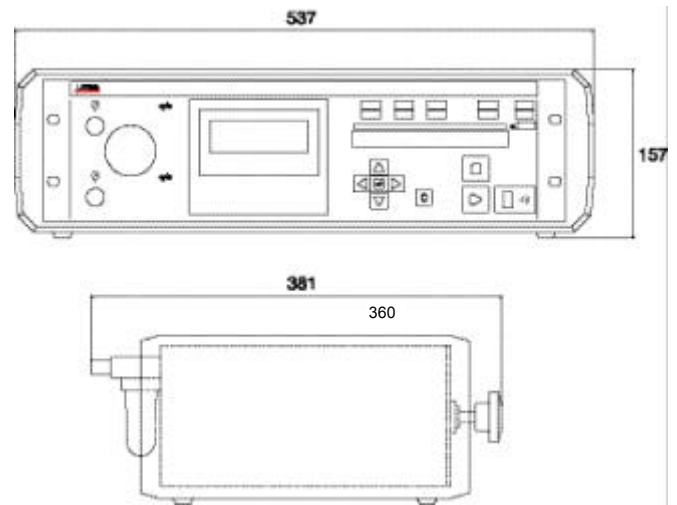

Technical specifications

- **Presentation**
Weight: about 15 kg
- **Interface**
Navigation keys
14 digit displays
4 line LCD display
Results indicators
- **External power supply**
Power supply: 90 - 260 V AC / 50 W
- **Air supply**
Clean and dry air required
Air quality standard to be applied (ISO 8573-1)
- **Temperature**
Operation : + 10°C to + 45°C
Storage : 0°C to + 60°C

Accessories

2 functions remote control
Printer
Parameter and results storage modules
ATEQ software (WINATEQ, S5 Demo)
Needle valve
Calibrated master leaks
Filtration kit
Sealing connectors
Consult our accessories documentation



Head Office:

15, rue des Dames - ZI des Dames - 78340 Les Clayes-Sous-Bois - France
☎ : + 33 (0)1 30 80 10 20 - Fax : + 33 (0)1 30 54 11 00 - e-mail : info@ateq.com
www.ateq.com